



16T-ES19

## Features

- Predestined for public surroundings (vandalism risk), industrial extreme surroundings
- Carbon contact technology
- High operating comfort thanks to our specially developed long-stroke keys
- Keycaps and front panel made of stainless steel
- Almost resistant to the effects of violence
- Key symbols are done by laser etching
- Any layout is possible
- Any customer-specific adaptations can be implemented on request
- Also available in housing, with trackball and with other number of keys
- Available with backlit keycaps

## Mechanical Data

- Dimensions of 111 x 111 x 39 mm
  - 3,25 mm travel keys with tactile feel
  - Operation force 0,65 N
  - 16 keys in compact layout
  - Ergonomic 15 mm keycaps
  - Durability > 10 million ops.
  - Storage temperature -40°C - +80°C
  - Operation temperature -30°C - +60°C
- Protection IP65, IK09

## Electrical Data

- Connection options: USB 2.0
- Power supply + 5 V/DC, 50 mA
- CE Compliant
- RoHS/Reach Compliant

  
control touch trust

## Drawing

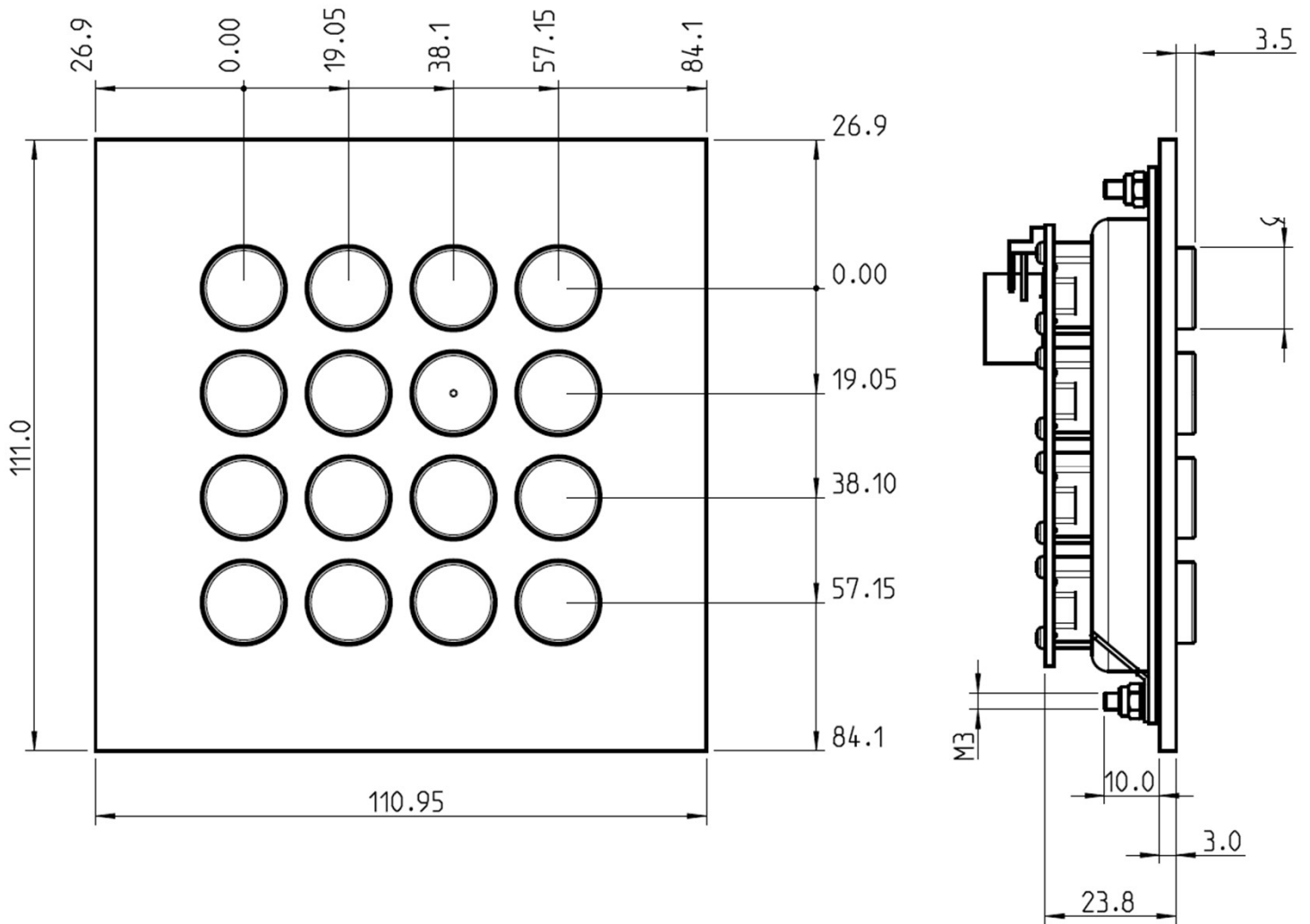

## Variants

Here is a selection of similar keypads. Are you interested in any of the following solutions? Just get in touch with us.

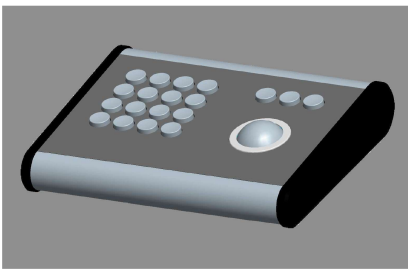

16T-ES19 GEH

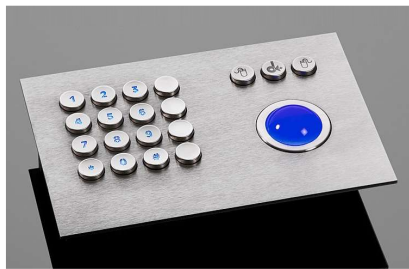

16T-ES19-TB HL



12T-ES HL



+49 7738 80241-0 ▶

support@printecds.com ▶

www.printecds.com ▶